

FEC60B  
24" Electric Freestanding Range

Porter & Charles

# FEC60B

## 24" Electric Freestanding Range



### RANGE FEATURES

- 24" (60cm) stainless steel slide-in electric range
- 63L(2.22cu.ft)oven capacity
- 5 cooking functions including True Fan convection
- ThermiC° hot air cooking technology for perfect cooking
- Plus triple glazed door
- 4 electric burners, 1 expandable
- Residual heat indicator
- Diamond glazed interior
- Fully programmable clock/timer with delay start and finish

### COOK TOP FEATURES

- 4 x Hi-Lite Zones
  - 2 x 145mm Hi-lite elements – 1, 200 Watts
  - 1 x 180mm Hi-lite element – 1, 800 Watts
  - 1 x 210mm Hi-lite element – 2, 200 Watts

### OVEN FEATURES

- 63L(2.22cu.ft)oven capacity
- Conventional oven cooking
- Classic bake
- Fan Assist cooking
- High bake
- Fan Grill

# Specifications

## FEC60B

### RANGE DIMENSIONS

- D:  $22\frac{5}{8}"$  x H:  $33\frac{7}{8}" - 36\frac{1}{4}"$  x W:  $23\frac{5}{8}"$
- D: 640 mm x H: 860 mm - 920 mm x W: 600 mm

### CUT-OUT DIMENSIONS

- H:  $24\frac{3}{16}"$  x W:  $23\frac{11}{16}"$
- H: min  $33\frac{7}{8}"$  x W: 602

### ELECTRICAL REQUIREMENTS

- 208 / 240 Volt 60Hz
- PORTER&CHARLES Ranges are supplied with 40 AMP corded plug

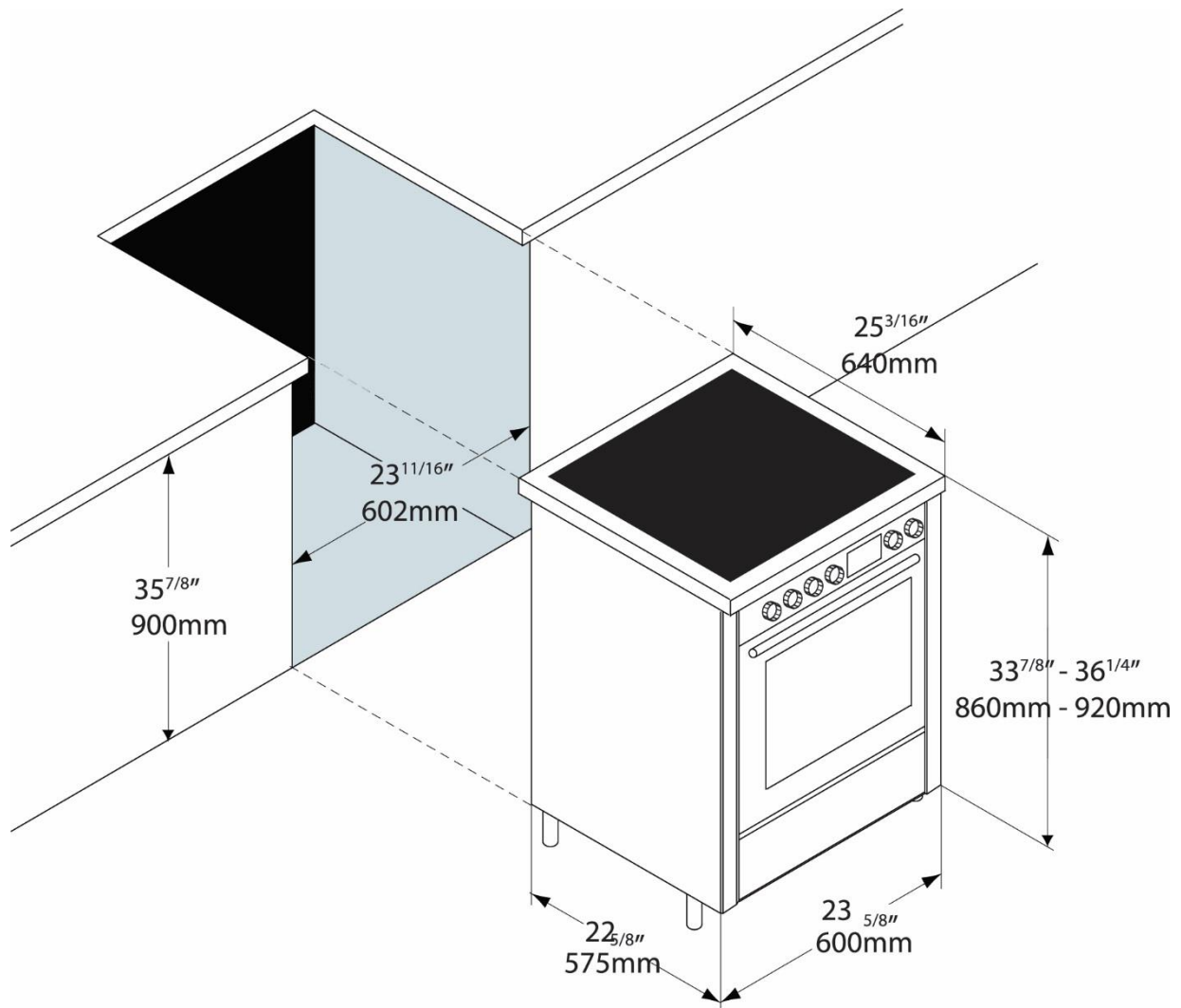

Specifications are subject to change without notice.

Detailed Specification Available at [www.porterandcharles.ca](http://www.porterandcharles.ca)

**Porter&Charles** products are designed and built to the highest standards.  
Each appliance is covered by a comprehensive 2 year parts and labour warranty.

Refer to product warranty policy for complete terms and conditions.

For Service & Parts  
**EURO-PARTS**

39822 Belgrave Rd,  
Belgrave, Ontario, Canada,  
N0G 1E0  
1.800.678.8352

---

Porter&Charles appliances are imported and distributed in North America by Euro-Line Appliances Inc.  
For more information visit  
[www.euro-line-appliances.com](http://www.euro-line-appliances.com) / [www.elawest.com](http://www.elawest.com)

***EURO-LINE APPLIANCES INC.***

871 Cranberry Court  
Oakville, ON L6L 6J7  
Canada  
Toll Free: 1-800-421-6332  
Showroom: 905-829-3980  
[marketing@euro-line-appliances.com](mailto:marketing@euro-line-appliances.com)

***EURO-LINE APPLIANCES WEST INC.***

2912 West 4th Ave  
Vancouver, BC V6K 1R2  
Canada  
Toll Free: 1-855-352-9378  
Showroom: 604-235-3980  
[info@elawest.com](mailto:info@elawest.com)